



Dry-break cartridge couplings without locking mechanism made of stainless steel. Available in six different sizes for modular block/plate assembly in sensitive environments. Different coupling sizes can be combined to one multicoupling depending on the application requirements.

No spillage and minimum dead space volume. No air inclusion when connecting. Tolerates deviations in axial alignment when installing.

**Working Temperature\***

-15°C up to +200°C (FKM)  
depending on the medium.

\* For temperatures below -15°C and over +200°C and depending on the medium, other seal variants (NBR, EPDM, FFKM) are available.

**Working Pressure\*\***

15 bar

\*\* maximum static working pressure with design factor 4 to 1.

**Material**

**Coupling:** AISI 316 L  
**Plug:** AISI 316 L  
**Seals:** FKM

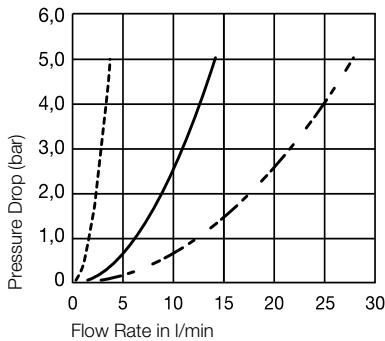
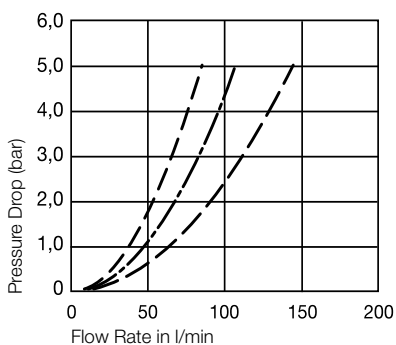
**Flow diagrams****Water (3, 4 and 6 mm)****Water (9, 12 and 19 mm)**

----- 3 mm      - - - - - 9 mm  
————— 4 mm      - - - - - 12 mm  
- - - - - 6 mm      - - - - - 19 mm

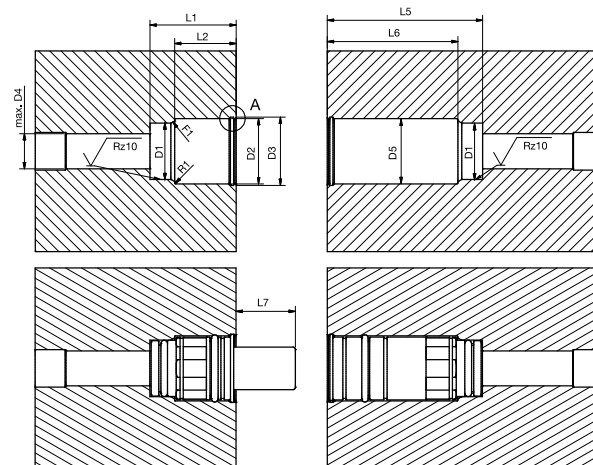
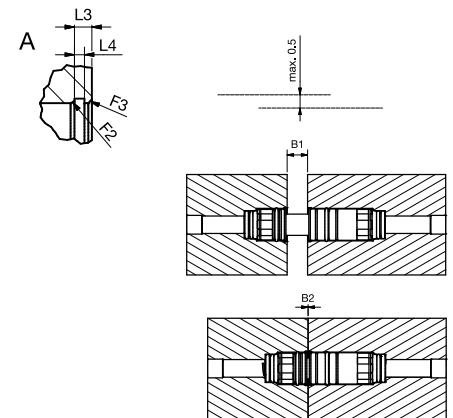
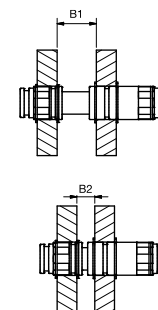
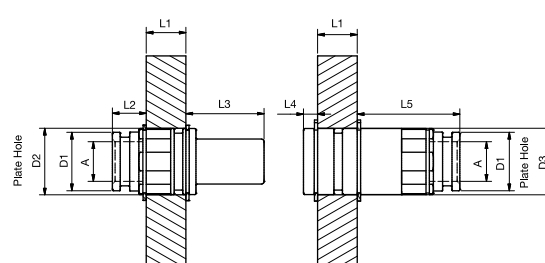
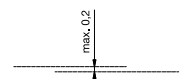
**Technical Features for block- and plate assembly – Tolerances for production of the holder on request.****Block Assembly****Misalignment for block assembly****Plate Assembly****Misalignment for plate assembly**



## Couplings – flat sealing

## Series 200KLEK

	Nominal Diameter mm	Connection A	L mm	L1 mm	D mm	D1 mm	Part Number
<p>Female Thread</p>	3	G 1/16	21,50		11,00		203KLIW08EVXEK
	4	G 1/8	35,70		16,00		204KLIW10EVXEK
	6	G 1/4	53,70		21,00		206KLIW13EVXEK
	9	G 3/8	59,10		25,00		209KLIW17EVXEK
	12	G 1/2	70,90		32,00		212KLIW21EVXEK
	19	G 3/4	77,00		44,00		219KLIW26EVXEK



## Plugs – flat sealing

## Series 200KLEK

	Nominal Diameter mm	Connection A	L mm	L1 mm	D mm	D1 mm	Part Number
<p>Female Thread</p>	3	G 1/16	28,70	10,75	11,00	5,30	203SLIW08EVXEK
	4	G 1/8	41,90	15,00	16,00	8,40	204SLIW10EVXEK
	6	G 1/4	51,15	19,00	21,00	12,50	206SLIW13EVXEK
	9	G 3/8	57,40	25,80	25,00	17,00	209SLIW17EVXEK
	12	G 1/2	69,70	28,00	30,00	20,00	212SLIW21EVXEK
	19	G 3/4	82,40	32,45	41,00	30,00	219SLIW26EVXEK

## Block Assembly

ND mm	L1 mm	L2 mm	L3 mm	L4 mm	L5 mm	L6 mm	L7 mm	D1 mm	D2 mm	D3 mm	D4 max. mm	D5 mm	R1 max. mm	F1	F2	F3	B1	B2
3	20,10	15,00	2,10	1,10	23,60	18,50	8,75	10,00	12,00	12,50	8,00	12,00	0,50	0,8x30°	–	0,5x45°	5,00	0
4	29,00	22,50	2,10	1,10	37,80	31,35	13,00	14,00	17,00	17,80	10,00	17,00	0,50	1,2x30°	0,5x30°	0,5x45°	8,65	0
6	34,25	26,65	2,10	1,10	55,80	48,20	17,00	18,50	22,00	23,00	12,00	22,00	0,50	1,3x30°	0,5x30°	0,5x45°	11,40	0
9	33,80	24,30	2,30	1,30	61,30	51,80	23,60	22,50	26,00	27,20	14,00	26,00	0,50	1,5x30°	0,5x30°	0,5x45°	16,30	0
12	44,00	34,40	2,30	1,30	73,20	63,60	25,80	28,00	31,00	32,70	16,00	33,00	0,50	1,5x30°	0,8x30°	0,5x45°	15,80	0
19	53,15	41,50	3,15	1,85	80,20	68,50	29,25	33,00	42,00	44,50	23,00	45,00	1,50	1,5x30°	1,0x30°	0,8x45°	20,30	0

## Plate Assembly

ND mm	L1 mm	L2 mm	L3 mm	L4 mm	L5 mm	L6 mm	L7 mm	D1 mm	D2 mm	D3 mm	Connecton A	F1	F2	F3	B1	B2
3	5,00	11,00	12,75	5,50	11,00			9,80	11,2	11,2	G 1/16				16,70	11,70
4	15,00	9,80	17,20	5,50	15,35			13,80	16,2	16,2	G 1/8				20,50	12,70
6	15,00	13,15	23,00	5,50	33,20			18,30	21,2	21,2	G 1/4				25,00	13,50
9	15,00	12,80	29,60	5,30	38,80			22,30	25,2	25,2	G 3/8				29,80	13,50
12	15,00	22,90	31,80	5,30	50,60			27,80	30,2	32,2	G 1/2				29,40	12,30
19	15,00	32,00	35,40	4,40	57,60			32,80	41,2	44,2	G 3/4				33,85	12,30

⚠ Please consider our security advices on the pages 12/13 ⚠