



# Needle Valves (U Series)

*Catalog 4110-U  
Revised, August 2004*



# U Series Needle Valves

## Introduction

Parker U Series Union Bonnet Valves have been engineered for use at pressures up to 6,000 (414 bar) and temperatures as high as 1,200 °F (649 °C). A non-rotating lower stem helps to extend packing life by removing rotation from the packing area. Stem packing below the threads isolates the thread lubricant from the flow, ensuring adequate lubrication regardless of the media.

## Features

- Union bonnet design ensures high integrity seal under severe service applications
- Packing below the power threads protects thread lubricants from media and isolates the lubricants from the media
- Dust seal in the packing nut protects stem threads from external contamination
- Stem swivel above the packing eliminates entrapment area and increases packing life
- Choice of Grafoil® or PTFE packing
- Choice of Regulating or Blunt stem types. Blunt stem type helps combat wire draw which may occur when two phase flow is present (i.e. steam service)
- 316 stainless steel construction
- Wide variety of US Customary and SI ports
- Panel mountable
- 100% factory tested

## Materials of Construction

Item #	Description	Material
* 1	Body	ASTM A 182, Type F316
2	Bonnet Nut	ASTM A 479, Type 316
* 3	Bonnet	ASTM A 479, Type 316
* 4	Lower Stem*	ASTM A 564, Type 630
5	Upper Stem	ASTM A 564, Type 630
6	Stem Guide	ASTM A 581, Type 416
7	Ball	440-C Stainless Steel
* 8	Bonnet Seal**	Nickel-Chromium-Iron Alloy
9	Packing Nut	ASTM A 479, Type 316
* 10	Packing***	Grafoil®
* 11	Packing Washer	316 Stainless Steel
12	Handle****	Aluminum
13	Handle Screw	316 Stainless Steel
14	Dust Seal*****	Nylon 6/6
15	Locking Nut	Stainless Steel

\* Wetted parts

\* Lower Stem material is ASTM A 276 Type 316 with HT option

\*\* Not required on U6 and U12 Series which have metal-to-metal seals

\*\*\* Optional PTFE Packing is available

\*\*\*\* Handle material is stainless steel with HT option

\*\*\*\*\* Dust Seal not available with HT option

Lubrication: Molybdenum disulfide with soft metallic fillers

## Specifications

### Pressure Rating:

6000 psig (414 bar) CWP

### Temperature Rating:

PTFE packing:

-65 °F to 450 °F (-54 °C to 232 °C)

Grafoil® packing:

-65 °F to 700 °F (-54 °C to 371 °C)

Grafoil® packing with HT option:

-65 °F to 1200 °F (-54 °C to 649 °C)

**Orifice:** .177" to .437" (4.5mm to 11.1mm)

**C<sub>v</sub>:** .53 to 3.55

### Pressure Rating and Tubing Selection:

For working pressures of A-LOK® and CPI™ tube connections, please see the [Instrument Tubing Selection Guide \(Bulletin 4200-TS\)](#), found in the Technical Section of the Parker Instrumentation Products Master Binder, or the Parker Instrument Tube Fitting Installation Manual (Bulletin 4200-B4).

For working pressures of valves with external or internal pipe threads, please see [Catalog 4260, Instrumentation Pipe Fittings](#).

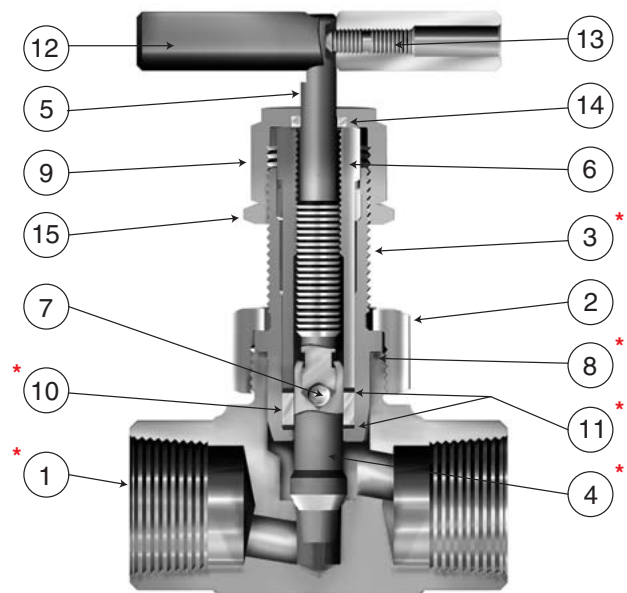

Model Shown: 16F-U16LR-G-SS

# U Series Needle Valves

## Pressure vs. Temperature

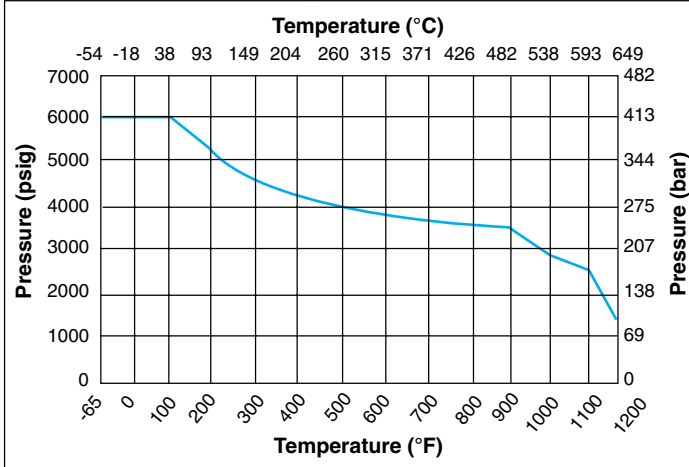

## Flow Characteristics

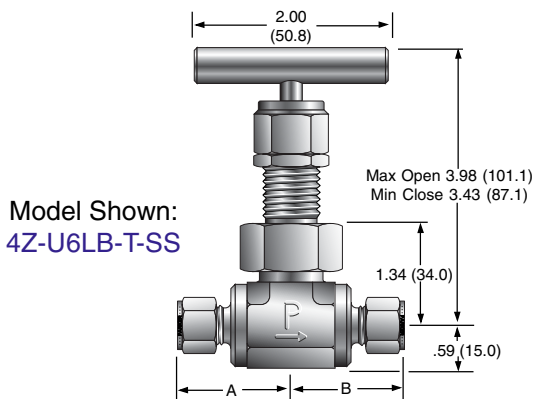
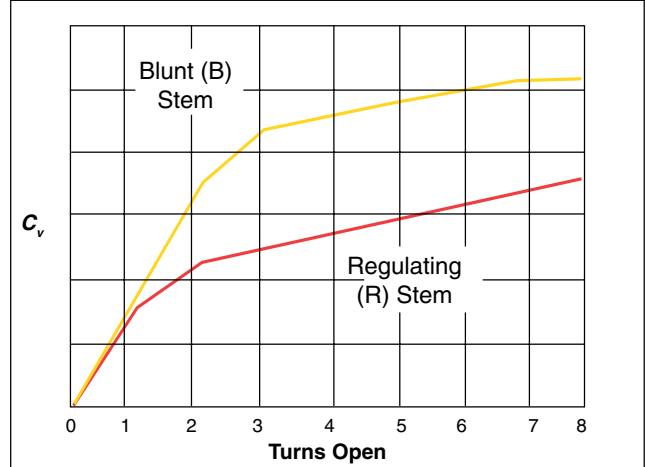

Panel Hole Diameter:  
0.65 (16.5)  
Max Panel Thickness:  
0.42 (10.7)

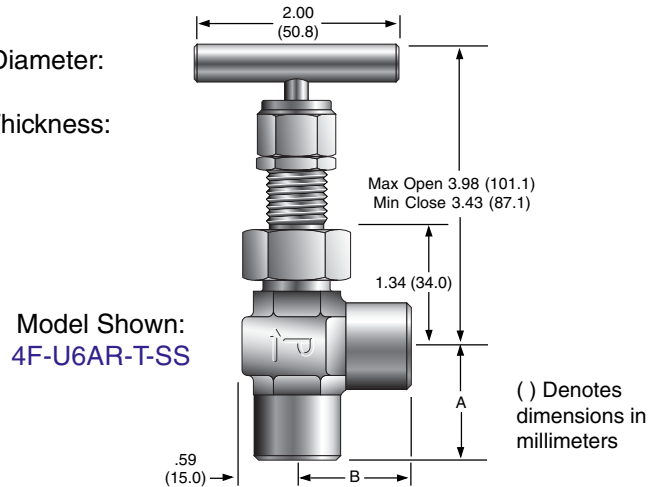

## U6 Series Dimensions / Flow Data

Basic Part Number		End Connections		Stem Type	Flow Data						Dimensions			
Inline	Angle	Inlet (Port 1)	Outlet (Port 2)		Orifice		Inline		Angle		A†		B†	
					Inch	mm	C <sub>v</sub>	x <sub>T</sub> *	C <sub>v</sub>	x <sub>T</sub> *	C <sub>v</sub>	x <sub>T</sub> *	Inch	mm
2F-U6LR	2F-U6AR	1/8" Female NPT		Regulating	0.188	4.8	0.58	0.83	0.77	0.70	1.00	25.4	1.00	25.4
2F-U6LB	2F-U6AB			Blunt			0.69	0.50	0.91	0.42				
4A-U6LR	4A-U6AR	1/4" Compression A-LOK®		Regulating	0.177	4.5	0.53	0.80	0.70	0.67	1.38	35.1	1.38	35.1
4A-U6LB	4A-U6AB			Blunt			0.65	0.48	0.86	0.40				
4F-U6LR	4F-U6AR	1/4" Female NPT		Regulating	0.228	5.8	0.78	0.95	1.04	0.80	1.03	26.2	1.03	26.2
4F-U6LB	4F-U6AB			Blunt			0.82	0.59	1.09	0.50				
4M-U6LR	4M-U6AR	1/4" Male NPT		Regulating	0.177	4.5	0.53	0.80	0.70	0.67	1.09	27.7	1.09	27.7
4M-U6LB	4M-U6AB			Blunt			0.65	0.48	0.86	0.40				
4W-U6LR	4W-U6AR	1/4" Socket Weld		Regulating	0.177	4.5	0.53	0.80	0.70	0.67	.91	23.1	.91	23.1
4W-U6LB	4W-U6AB			Blunt			0.65	0.48	0.86	0.40				
4Z-U6LR	4Z-U6AR	1/4" Compression CPI™		Regulating	0.177	4.5	0.53	0.80	0.70	0.67	1.38	35.1	1.38	35.1
4Z-U6LB	4Z-U6AB			Blunt			0.65	0.48	0.86	0.40				
M6A-U6LR	M6A-U6AR	6mm Compression A-LOK®		Regulating	0.177	4.5	0.53	0.80	0.70	0.67	1.38	35.1	1.38	35.1
M6A-U6LB	M6A-U6AB			Blunt			0.65	0.48	0.86	0.40				
M6Z-U6LR	M6Z-U6AR	6mm Compression CPI™		Regulating	0.177	4.5	0.53	0.80	0.70	0.67	1.38	35.1	1.38	35.1
M6Z-U6LB	M6Z-U6AB			Blunt			0.65	0.48	0.86	0.40				
M8A-U6LR	M8A-U6AR	8mm Compression A-LOK®		Regulating	0.177	4.5	0.53	0.80	0.70	0.67	1.38	35.1	1.38	35.1
M8A-U6LB	M8A-U6AB			Blunt			0.65	0.48	0.86	0.40				
M8Z-U6LR	M8Z-U6AR	8mm Compression CPI™		Regulating	0.177	4.5	0.53	0.80	0.70	0.67	1.38	35.1	1.38	35.1
M8Z-U6LB	M8Z-U6AB			Blunt			0.65	0.48	0.86	0.40				

\* Tested in accordance with ISA S75.02. Gas flow will be choked when  $P_1 - P_2 / P_1 = X_T$

† For CPI™ and A-LOK® dimensions are measured with nuts in the finger tight position

# U Series Needle Valves

Model Shown:  
6F-U12LB-G-SS-HT

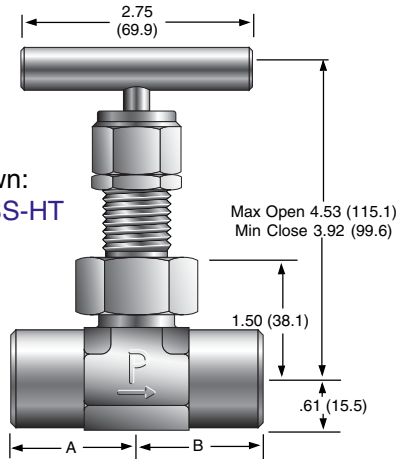

Panel Hole Diameter:  
0.83 (21.1)  
Max Panel Thickness:  
0.61 (15.5)

Model Shown:  
M12A-U12AB-T-SS

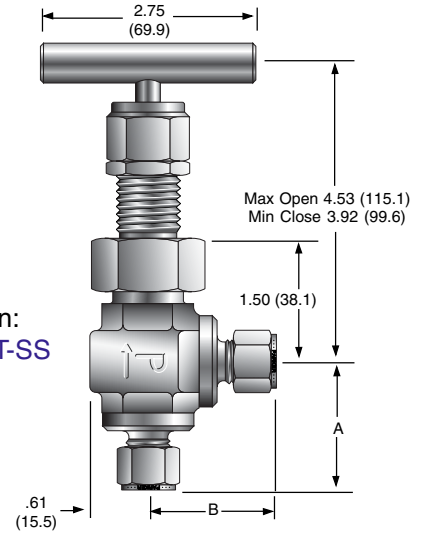

## U12 Series Dimensions / Flow Data

( ) Denotes dimensions in millimeters

Basic Part Number		End Connections		Stem Type	Flow Data						Dimensions			
Inline	Angle	Inlet (Port 1)	Outlet (Port 2)		Orifice		Inline		Angle		A†		B†	
					Inch	mm	$C_v$	$x_T^*$	$C_v$	$x_T^*$	$C_v$	$x_T^*$	Inch	mm
4A-U12LR 4A-U12LB	4A-U12AR 4A-U12AB	1/4" Compression A-LOK®		Regulating Blunt	0.125	3.2	0.44 0.51	0.57 0.40	0.60 0.68	0.49 0.33	1.39	35.3	1.39	35.3
4F-U12LR 4F-U12LB	4F-U12AR 4F-U12AB	1/4" Female NPT		Regulating Blunt	0.250	6.4	0.94 1.03	0.65 0.60	1.25 1.37	0.55 0.51	1.13	28.7	1.13	28.7
4Z-U12LR 4Z-U12LB	4Z-U12AR 4Z-U12AB	1/4" Compression CPI™		Regulating Blunt	0.125	3.2	0.44 0.51	0.57 0.40	0.60 0.68	0.49 0.33	1.39	35.3	1.39	35.3
6A-U12LR 6A-U12LB	6A-U12AR 6A-U12AB	3/8" Compression A-LOK®		Regulating Blunt	0.187	4.7	0.69 0.77	0.61 0.50	0.92 1.02	0.52 0.42	1.60	40.6	1.60	40.6
6F-U12LR 6F-U12LB	6F-U12AR 6F-U12AB	3/8" Female NPT		Regulating Blunt	0.312	7.9	1.19 1.31	0.78 0.80	1.58 1.74	0.66 0.68	1.30	33.0	1.30	33.0
6W-U12LR 6W-U12LB	6W-U12AR 6W-U12AB	3/8" Tube Socket Weld		Regulating Blunt	0.228	5.8	0.85 0.94	0.64 0.57	1.13 1.25	0.54 0.48	1.13	28.7	1.13	28.7
6Z-U12LR 6Z-U12LB	6Z-U12AR 6Z-U12AB	3/8" Compression CPI™		Regulating Blunt	0.187	4.7	0.69 0.77	0.61 0.50	0.92 1.02	0.52 0.42	1.60	40.6	1.60	40.6
8A-U12LR 8A-U12LB	8A-U12AR 8A-U12AB	1/2" Compression A-LOK®		Regulating Blunt	0.250	6.4	0.94 1.03	0.65 0.60	1.25 1.37	0.55 0.51	1.49	37.8	1.49	37.8
8F-U12LR 8F-U12LB	8F-U12AR 8F-U12AB	1/2" Female NPT		Regulating Blunt	0.312	7.9	1.19 1.31	0.78 0.80	1.58 1.74	0.66 0.68	1.50	38.1	1.50	38.1
8W-U12LR 8W-U12LB	8W-U12AR 8W-U12AB	1/2" Tube Socket Weld		Regulating Blunt	0.312	7.9	1.19 1.31	0.78 0.80	1.58 1.74	0.66 0.68	1.25	31.8	1.25	31.8
8Z-U12LR 8Z-U12LB	8Z-U12AR 8Z-U12AB	1/2" Compression CPI™		Regulating Blunt	0.250	6.4	0.94 1.03	0.65 0.60	1.25 1.37	0.55 0.51	1.49	37.8	1.49	37.8
M10A-U12LR M10A-U12LB	M10A-U12AR M10A-U12AB	10mm Compression A-LOK®		Regulating Blunt	0.250	6.4	0.94 1.03	0.65 0.60	1.25 1.37	0.55 0.51	1.53	38.9	1.53	38.9
M10Z-U12LR M10Z-U12LB	M10Z-U12AR M10Z-U12AB	10mm Compression CPI™		Regulating Blunt	0.250	6.4	0.94 1.03	0.65 0.60	1.25 1.37	0.55 0.51	1.53	38.9	1.53	38.9
M12A-U12LR M12A-U12LB	M12A-U12AR M12A-U12AB	12mm Compression A-LOK®		Regulating Blunt	0.312	7.9	1.19 1.31	0.78 0.80	1.58 1.74	0.66 0.68	1.70	43.2	1.70	43.2
M12Z-U12LR M12Z-U12LB	M12Z-U12AR M12Z-U12AB	12mm Compression CPI™		Regulating Blunt	0.312	7.9	1.19 1.31	0.78 0.80	1.58 1.74	0.66 0.68	1.70	43.2	1.70	43.2
M14A-U12LR M14A-U12LB	M14A-U12AR M14A-U12AB	14mm Compression A-LOK®		Regulating Blunt	0.312	7.9	1.19 1.31	0.78 0.80	1.58 1.74	0.66 0.68	1.70	43.2	1.70	43.2
M14Z-U12LR M14Z-U12LB	M14Z-U12AR M14Z-U12AB	14mm Compression CPI™		Regulating Blunt	0.312	7.9	1.19 1.31	0.78 0.80	1.58 1.74	0.66 0.68	1.70	43.2	1.70	43.2

\* Tested in accordance with ISA S75.02. Gas flow will be choked when  $P_1 - P_2 / P_1 = x_T$ .  
† For CPI™ and A-LOK®, dimensions are measured with nuts in the finger tight position

# U Series Needle Valves

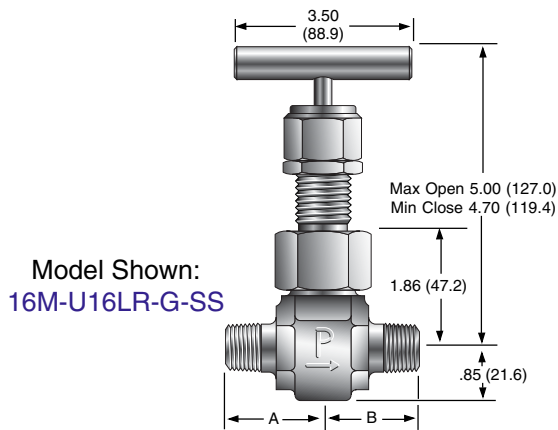

Model Shown:  
16M-U16LR-G-SS

Panel Hole Diameter:  
1.02 (25.9)  
Max Panel Thickness:  
0.62 (15.7)

Model Shown:  
16M16F-U16AB-T-SS

( ) Denotes dimensions in millimeters

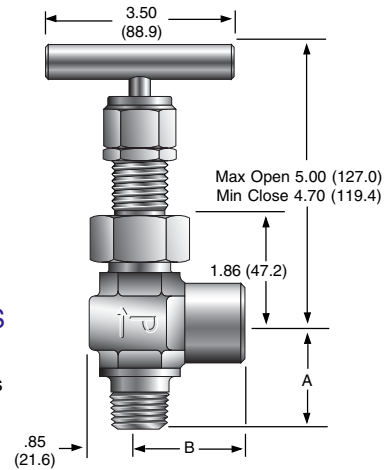

## U16 Series Dimensions / Flow Data

Basic		End Connections		Stem Type	Flow Data					Dimensions				
Part Number		Inlet (Port 1)	Outlet (Port 2)		Orifice		Inline		Angle		A†		B†	
Inline	Angle				Inch	mm	$C_v$	$x_T^*$	$C_v$	$x_T^*$	Inch	mm	Inch	mm
8A-U16LR 8A-U16LB	8A-U16AR 8A-U16AB	1/2" Compression A-LOK®		Regulating Blunt	0.394	10.0	1.59 1.90	0.73 0.95	2.11 2.53	0.62 0.81	1.97	50.0	1.97	50.0
8F-U16LR 8F-U16LB	8F-U16AR 8F-U16AB	1/2" Female NPT		Regulating Blunt	0.437	11.1	1.82 2.67	0.72 0.80	2.42 3.55	0.61 0.68	1.56	39.6	1.56	39.6
8M-U16LR 8M-U16LB	8M-U16AR 8M-U16AB	1/2" Male NPT		Regulating Blunt	0.437	11.1	1.82 2.67	0.72 0.80	2.42 3.55	0.61 0.68	1.92	48.8	1.92	48.8
8PSW-U16LR 8PSW-U16LB	8PSW-U16AR 8PSW-U16AB	1/2" Pipe Socket Weld		Regulating Blunt	0.437	11.1	1.82 2.67	0.72 0.80	2.42 3.55	0.61 0.68	1.56	39.6	1.56	39.6
8W-U16LR 8W-U16LB	8W-U16AR 8W-U16AB	1/2" Tube Socket Weld		Regulating Blunt	0.394	10.0	1.59 1.90	0.73 0.95	2.11 2.53	0.62 0.81	1.69	42.9	1.69	42.9
8Z-U16LR 8Z-U16LB	8Z-U16AR 8Z-U16AB	1/2" Compression CPI™		Regulating Blunt	0.394	10.0	1.59 1.90	0.73 0.95	2.11 2.53	0.62 0.81	1.97	50.0	1.97	50.0
12A-U16LR 12A-U16LB	12A-U16AR 12A-U16AB	3/4" Compression A-LOK®		Regulating Blunt	0.437	11.1	1.82 2.67	0.72 0.80	2.42 3.55	0.61 0.68	1.97	50.0	1.97	50.0
12F-U16LR 12F-U16LB	12F-U16AR 12F-U16AB	3/4" Female NPT		Regulating Blunt	0.437	11.1	1.82 2.67	0.72 0.80	2.42 3.55	0.61 0.68	1.63	41.4	1.63	41.4
12M-U16LR 12M-U16LB	12M-U16AR 12M-U16AB	3/4" Male NPT		Regulating Blunt	0.437	11.1	1.82 2.67	0.72 0.80	2.42 3.55	0.61 0.68	1.63	41.4	1.63	41.4
12PSW-U16LR 12PSW-U16LB	12PSW-U16AR 12PSW-U16AB	3/4" Pipe Socket Weld		Regulating Blunt	0.437	11.1	1.82 2.67	0.72 0.80	2.42 3.55	0.61 0.68	1.56	39.6	1.56	39.6
12W-U16LR 12W-U16LB	12W-U16AR 12W-U16AB	3/4" Tube Socket Weld		Regulating Blunt	0.437	11.1	1.82 2.67	0.72 0.80	2.42 3.55	0.61 0.68	1.56	39.6	1.56	39.6
12Z-U16LR 12Z-U16LB	12Z-U16AR 12Z-U16AB	3/4" Compression CPI™		Regulating Blunt	0.437	11.1	1.82 2.67	0.72 0.80	2.42 3.55	0.61 0.68	1.97	50.0	1.97	50.0
16A-U16LR 16A-U16LB	16A-U16AR 16A-U16AB	1" Compression A-LOK®		Regulating Blunt	0.437	11.1	1.82 2.67	0.72 0.80	2.42 3.55	0.61 0.68	1.97	50.0	1.97	50.0
16F-U16LR 16F-U16LB	16F-U16AR 16F-U16AB	1" Female NPT		Regulating Blunt	0.437	11.1	1.82 2.67	0.72 0.80	2.42 3.55	0.61 0.68	1.81	46.0	1.81	46.0
16M-U16LR 16M-U16LB	16M-U16AR 16M-U16AB	1" Male NPT		Regulating Blunt	0.437	11.1	1.82 2.67	0.72 0.80	2.42 3.55	0.61 0.68	1.81	46.0	1.81	46.0
16Z-U16LR 16Z-U16LB	16Z-U16AR 16Z-U16AB	1" Compression CPI™		Regulating Blunt	0.437	11.1	1.82 2.67	0.72 0.80	2.42 3.55	0.61 0.68	1.97	50.0	1.97	50.0
M12A-U16LR M12A-U16LB	M12A-U16AR M12A-U16AB	12mm Compression A-LOK®		Regulating Blunt	0.394	10.0	1.59 1.90	0.73 0.95	2.11 2.53	0.62 0.81	1.97	50.0	1.97	50.0
M12Z-U16LR M12Z-U16LB	M12Z-U16AR M12Z-U16AB	12mm Compression CPI™		Regulating Blunt	0.394	10.0	1.59 1.90	0.73 0.95	2.11 2.53	0.62 0.81	1.97	50.0	1.97	50.0
M20A-U16LR M20A-U16LB	M20A-U16AR M20A-U16AB	20mm Compression A-LOK®		Regulating Blunt	0.437	11.1	1.82 2.67	0.72 0.80	2.42 3.55	0.61 0.68	1.97	50.0	1.97	50.0
M20Z-U16LR M20Z-U16LB	M20Z-U16AR M20Z-U16AB	20mm Compression CPI™		Regulating Blunt	0.437	11.1	1.82 2.67	0.72 0.80	2.42 3.55	0.61 0.68	1.97	50.0	1.97	50.0
M25A-U16LR M25A-U16LB	M25A-U16AR M25A-U16AB	25mm Compression A-LOK®		Regulating Blunt	0.437	11.1	1.82 2.67	0.72 0.80	2.42 3.55	0.61 0.68	1.97	50.0	1.97	50.0
M25Z-U16LR M25Z-U16LB	M25Z-U16AR M25Z-U16AB	25mm Compression CPI™		Regulating Blunt	0.437	11.1	1.82 2.67	0.72 0.80	2.42 3.55	0.61 0.68	1.97	50.0	1.97	50.0

\* Tested in accordance with ISA S75.02. Gas flow will be choked when  $P_1 - P_2 / P_1 = x_T$

† For CPI™ and A-LOK® dimensions are measured with nuts in the finger tight position

# U Series Needle Valves

## How to Order

The correct part number is easily derived from the following number sequence. The six product characteristics required are coded as shown below. \*Note: If the inlet and outlet ports are the same, eliminate the outlet port designator.

Example: 4Z - \* - U6A R - G - SS  
 (1) (2) (3) (4) (5) (6)  
 Inlet Outlet Valve Stem Packing Body  
 Port Port Series Type Material

Describes an angle pattern U6 Series needle valve equipped with 1/4" CPI™ compression inlet and outlet ports, a regulating stem type, Grafoil® packing, stainless steel construction.

(1) Inlet Port	(2) Outlet Port	(3) Valve Series	(4) Stem Type	(5) Packing	(6) Body Material
2F, 4A, 4F, 4M, 4W, 4Z, M6A, M6Z, M8A, M8Z		U6A U6L	B - Blunt  R - Regulating	T - PTFE  G - Grafoil®	SS- Stainless Steel
4A, 4F, 4Z, 6A, 6F, 6W, 6Z, 8A, 8F, 8W, 8Z, 10A, 10Z, 12A, 12Z, M10A, M10Z, M12A, M12Z, M14A, M14Z		U12A U12L			
8A, 8F, 8M, 8PSW, 8W, 8Z, 12A, 12F, 12M, 12PSW, 12W, 12Z, 16A, 16F, 16M, 16Z, M12A, M12Z, M20A, M20Z, M25A, M25Z		U16A U16L			

## How to Order Options

**High Temperature** - Add the suffix **-HT** to the end of the part number to receive valves with a 316 stainless steel lower stem and stainless steel handle. Example: 4M-U6LB-G-SS-**HT**

**Oxygen Cleaning** - Add the suffix **-C3** to the end of the part number to receive valves cleaned and assembled for oxygen service in accordance with Parker Specification ES8003. Example: 8A-U12LR-T-SS-**C3**

**Stainless Steel Bar Handle** - To obtain valves with stainless steel bar handle, add the suffix **-ST** to the end of the part number. Example: 12Z-U16AB-T-SS-**ST**

## How to Order Maintenance Kits

**Stainless Steel T-Bar Handles with Handle Screw** - U6: V4-BAR-HANDLE-SS; U12: U12-BAR-HANDLE-SS; U16: U16-BAR-HANDLE-SS

**Aluminum T-Bar Handles with Handle Screw** - U6: V4-BAR-HANDLE-AL; U12: U12-BAR-HANDLE-AL; U16: U16-BAR-HANDLE-AL

**Panel Mounting Nuts** - U6: U6-LOCKNUT; U12: U12-LOCKNUT; U16: U16-LOCKNUT

**PTFE Packing Kits** - Consists of One PTFE Packing; One Dust Seal; Maintenance Instructions. Kit-Valve Series-T. Example: **KIT-U12-T**

**Grafoil® Packing Kits** - Consists of One Grafoil® Packing; One Dust Seal; Maintenance Instructions. Kit-Valve Series-G. Example: **KIT-U16-G**

Grafoil® is a registered trademark of UCAR Carbon Technology Corporation

### WARNING

FAILURE, IMPROPER SELECTION OR IMPROPER USE OF THE PRODUCTS AND/OR SYSTEMS DESCRIBED HEREIN OR RELATED ITEMS CAN CAUSE DEATH, PERSONAL INJURY AND PROPERTY DAMAGE.

This document and other information from Parker Hannifin Corporation, its subsidiaries and authorized distributors provide product and/or system options for further investigation by users having technical expertise. It is important that you analyze all aspects of your application and review the information concerning the product or system in the current product catalog. Due to the variety of operating conditions and applications for these products or systems, the user, through its own analysis and testing, is solely responsible for making the final selection of the products and systems and assuring that all performance, safety and warning requirements of the application are met.

The products described herein, including without limitation, product features, specifications, designs, availability and pricing, are subject to change by Parker Hannifin Corporation and its subsidiaries at any time without notice.

© Copyright 2004, Parker Hannifin Corporation. All Rights Reserved.



# Offer of Sale

The items described in this document and other documents or descriptions provided by Parker Hannifin Corporation, its subsidiaries and its authorized distributors are hereby offered for sale at prices to be established by Parker Hannifin Corporation, its subsidiaries and its authorized distributors. This offer and its acceptance by any customer ("Buyer") shall be governed by all of the following Terms and Conditions. Buyer's order for any such items, when communicated to Parker Hannifin Corporation, its subsidiary or an authorized distributor ("Seller") verbally or in writing, shall constitute acceptance of this offer.

1. **Terms and Conditions of Sale:** All descriptions, quotations, proposals, offers, acknowledgments, acceptances and sales of Seller's products are subject to and shall be governed exclusively by the terms and conditions stated herein. Buyer's acceptance of any offer to sell is limited to these terms and conditions. Any terms or conditions in addition to, or inconsistent with those stated herein, proposed by Buyer in any acceptance of an offer by Seller, are hereby objected to. No such additional, different or inconsistent terms and conditions shall become part of the contract between Buyer and Seller unless expressly accepted in writing by Seller. Seller's acceptance of any offer to purchase by Buyer is expressly conditional upon Buyer's assent to all the terms and conditions stated herein, including any terms in addition to, or inconsistent with those contained in Buyer's offer. Acceptance of Seller's products shall in all events constitute such assent.

2. **Payment:** Payment shall be made by Buyer net 30 days from the date of delivery of the items purchased hereunder. Amounts not timely paid shall bear interest at the maximum rate permitted by law for each month or portion thereof that the Buyer is late in making payment. Any claims by Buyer for omissions or shortages in a shipment shall be waived unless Seller receives notice thereof within 30 days after Buyer's receipt of the shipment.

3. **Delivery:** Unless otherwise provided on the face hereof, delivery shall be made F.O.B. Seller's plant. Regardless of the method of delivery, however, risk of loss shall pass to Buyer upon Seller's delivery to a carrier. Any delivery dates shown are approximate only and Seller shall have no liability for any delays in delivery.

4. **Warranty:** Seller warrants that items sold hereunder shall be free from defects in material or workmanship. THIS WARRANTY COMPRISES THE SOLE AND ENTIRE WARRANTY PERTAINING TO ITEMS PROVIDED HEREUNDER. SELLER MAKES NO OTHER WARRANTY, GUARANTEE, OR REPRESENTATION OF ANY KIND WHATSOEVER. ALL OTHER WARRANTIES, INCLUDING BUT NOT LIMITED TO, MERCHANTABILITY AND FITNESS FOR PURPOSE, WHETHER EXPRESS, IMPLIED, OR ARISING BY OPERATION OF LAW, TRADE USAGE, OR COURSE OF DEALING ARE HEREBY DISCLAIMED.

NOTWITHSTANDING THE FOREGOING, THERE ARE NO WARRANTIES WHATSOEVER ON ITEMS BUILT OR ACQUIRED WHOLLY OR PARTIALLY, TO BUYER'S DESIGNS OR SPECIFICATIONS.

5. **Limitation Of Remedy:** SELLER'S LIABILITY ARISING FROM OR IN ANY WAY CONNECTED WITH THE ITEMS SOLD OR THIS CONTRACT SHALL BE LIMITED EXCLUSIVELY TO REPAIR OR REPLACEMENT OF THE ITEMS SOLD, AT SELLER'S SOLE OPTION. IN NO EVENT SHALL SELLER BE LIABLE FOR ANY INCIDENTAL, CONSEQUENTIAL OR SPECIAL DAMAGES OF ANY KIND OR NATURE WHATSOEVER, INCLUDING BUT NOT LIMITED TO LOST PROFITS ARISING FROM OR IN ANY WAY CONNECTED WITH THIS AGREEMENT OR ITEMS SOLD HEREUNDER, WHETHER ALLEGED TO ARISE FROM BREACH OF CONTRACT, EXPRESS OR IMPLIED WARRANTY, OR IN TORT, INCLUDING WITHOUT LIMITATION, NEGLIGENCE, FAILURE TO WARN OR STRICT LIABILITY.

6. **Changes, Reschedules and Cancellations:** Buyer may request to modify the designs or specifications for the items sold hereunder as well as the quantities and delivery dates thereof, or may request to cancel all or part of this order, however, no such requested modification or cancellation shall become part of the contract between Buyer and Seller unless accepted by Seller in a written amendment to this Agreement. Acceptance of any such requested modification or cancellation shall be at Seller's discretion, and shall be upon such terms and conditions as Seller may require.

7. **Special Tooling:** A tooling charge may be imposed for any special tooling, including without limitation, dies, fixtures, molds and patterns, acquired to manufacture items sold pursuant to this contract. Such special tooling shall be and remain Seller's property notwithstanding payment of any charges by Buyer. In no event will Buyer acquire any interest in apparatus belonging to Seller which is utilized in the manufacture of the items sold hereunder, even if such apparatus has been specially converted or adapted for such manufacture and not withstanding any charges paid by Buyer. Unless otherwise agreed, Seller shall have the right to alter, discard or otherwise dispose of any special tooling or other property in its sole discretion at any time.

8. **Buyer's Property:** Any designs, tools, patterns, materials, drawings, confidential information or equipment furnished by Buyer or any other items which become Buyer's property, may be considered obsolete and may be destroyed by Seller after two (2) consecutive years have elapsed without Buyer placing an order for the items which are manufactured using such property, Seller shall not be responsible for any loss or damage to such property while it is in Seller's possession or control.

9. **Taxes:** Unless otherwise indicated on the face hereof, all prices and charges are exclusive of excise, sales, use, property, occupational or like taxes which may be imposed by any taxing authority upon the manufacture, sale or delivery of the items sold hereunder. If any such taxes must be paid by Seller or if Seller is liable for the collection of such tax, the amount thereof shall be in addition to the amounts for the items sold. Buyer agrees to pay all such taxes or to reimburse Seller therefore upon receipt of its invoice. If Buyer claims exemption from any sales, use or other tax imposed by any taxing authority, Buyer shall save Seller harmless from and against any such tax, together with any interest or penalties thereon which may be assessed if the items are held to be taxable.

10. **Indemnity For Infringement of Intellectual Property Rights:** Seller shall have no liability for infringement of any patents, trademarks, copyrights, trade dress, trade secrets or similar rights except as provided in this Part 10. Seller will defend and indemnify Buyer against allegations of infringement of U.S. Patents, U.S. Trademarks, copyrights, trade dress and trade secrets (hereinafter 'Intellectual Property Rights'). Seller will defend at its expense and will pay the cost of any settlement or damages awarded in an action brought against Buyer based on an allegation that an item sold pursuant to this contract infringes the Intellectual Property Rights of a third party. Seller's obligation to defend and indemnify Buyer is contingent on Buyer notifying Seller within ten (10) days after Buyer becomes aware of such allegations of infringement, and Seller having sole control over the defense of any allegations or actions including all negotiations for settlement or compromise. If an item sold hereunder is subject to a claim that it infringes the Intellectual Property Rights of a third party, Seller may, at its sole expense and option, procure for Buyer the right to continue using said item, replace or modify said item so as to make it noninfringing, or offer to accept return of said item and return the purchase price less a reasonable allowance for depreciation. Notwithstanding the foregoing, Seller shall have no liability for claims of infringement based on information provided by Buyer, or directed to items delivered hereunder for which the designs are specified in whole or part by Buyer, or infringements resulting from the modification, combination or use in a system of any item sold hereunder. The foregoing provisions of this Part 10 shall constitute Seller's sole and exclusive liability and Buyer's sole and exclusive remedy for infringement of Intellectual Property Rights.

If a claim is based on information provided by Buyer or if the design for an item delivered hereunder is specified in whole or in part by Buyer, Buyer shall defend and indemnify Seller for all costs, expenses or judgments resulting from any claim that such item infringes any patent, trademark, copyright, trade dress, trade secret or any similar right.

11. **Force Majeure:** Seller does not assume the risk of and shall not be liable for delay or failure to perform any of Seller's obligations by reason of circumstances beyond the reasonable control of Seller (hereinafter 'Events of Force Majeure'). Events of Force Majeure shall include without limitation, accidents, acts of God, strikes or labor disputes, acts, laws, rules or regulations of any government or government agency, fires, floods, delays or failures in delivery of carriers or suppliers, shortages of materials and any other cause beyond Seller's control.

12. **Entire Agreement/Governing Law:** The terms and conditions set forth herein, together with any amendments, modifications and any different terms or conditions expressly accepted by Seller in writing, shall constitute the entire Agreement concerning the items sold, and there are no oral or other representations or agreements which pertain thereto. This Agreement shall be governed in all respects by the law of the State of Ohio. No actions arising out of the sale of the items sold hereunder or this Agreement may be brought by either party more than two (2) years after the cause of action accrues.

11/98-P

---

Parker仪表管阀件联系方式：

信德迈科技(北京)有限公司 CNMEC Technology Company

地址：北京朝阳区望京街10号望京SOHO-T1-C座2115室

邮编：100102

电话：010-8428 2935, 8428 9077, 8428 3983

手机：139 1096 2635

Http：[//www.cnmec.biz](http://www.cnmec.biz)

E-mail：[sales@cnmec.biz](mailto:sales@cnmec.biz)

传真：010-8428 8762

