

# 77 Series

High Pressure Quick Couplings  
1/4" Body Size



## Flush Valve Minimizes Fluid Loss in High Pressure Applications

Parker's 77 Series quick couplings are available in a wide range of end fittings that are suitable for high pressure applications.

These heavy duty couplings can be configured to function as double shut off with non-spill valves in both halves or single shut off when used with a plain (unvalved) nipple.

Applications include:

- Hydraulic test stands
- Hydrotesting
- Off shore drilling and production



## Contact Information:

Parker Hannifin Corporation  
**Quick Coupling Division**  
8145 Lewis Road  
Minneapolis, MN 55427

phone 763 544 7781  
fax 763 544 3418  
qcd\_sales@parker.com

[www.parker.com/quickcouplings](http://www.parker.com/quickcouplings)

## 77 Series Features:

- Flush valve minimizes fluid loss and air inclusion
- Rugged heavy duty construction with superior flow characteristics
- Operating pressures up to 36,000 psi (2482 bar)
- Materials - high strength steel with Zinc Trivalent Chromate plating or electroless nickel plating as well as 316 stainless steel
- Proven dog-lock mechanism provides safe, positive connections and eliminates ball brinelling
- Internal sleeve lock standard as safety feature
- Available in 1/4" size
- End fitting versatility due to two piece body construction



ENGINEERING YOUR SUCCESS.

# Technical and Dimensional Information

## Dimensions

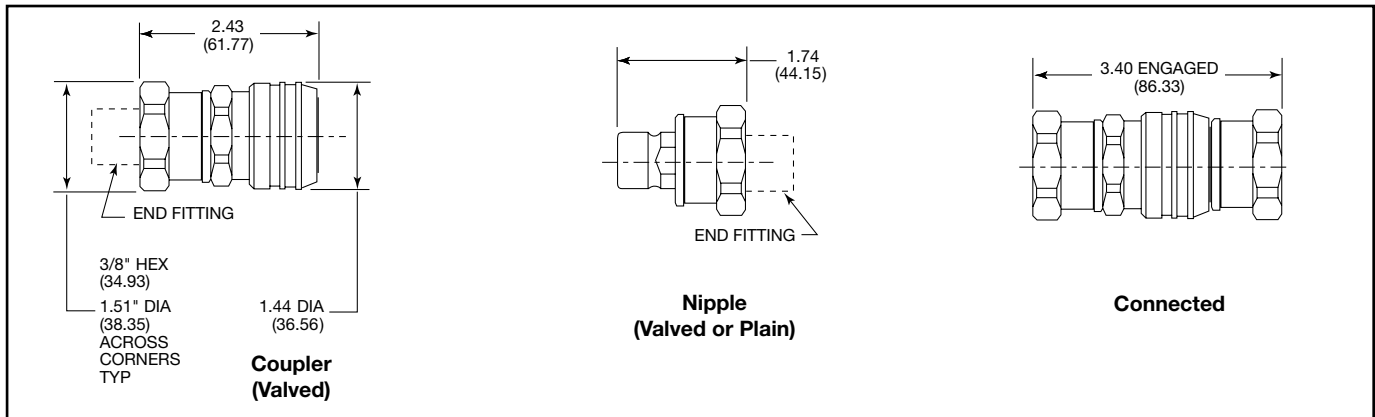

## Pressure Ratings

Size	Spillage (cc)	Air Inclusion (cc)	Steel				316 Stainless Steel			
			Maximum Working		Minimum Burst		Maximum Working		Minimum Burst	
			psi	Bar	psi	Bar	psi	Bar	psi	Bar
1/4"	.04	.04	36,000	2482	72,000	4965	20,000	1379	40,000	2759

## Pressure Loss vs. Flow

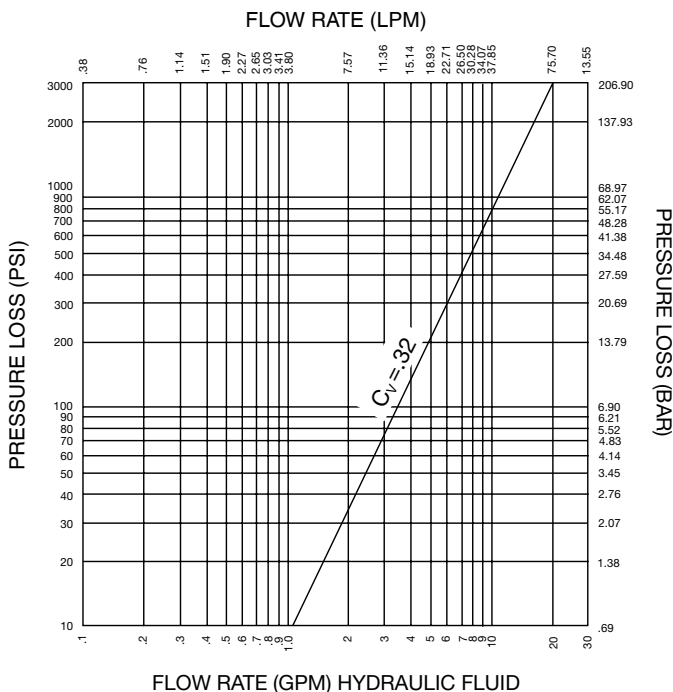

Data applies to parts with female NPTF end fittings

## Ordering Information

**S** **77** **C** **4** **SF562CX** **V**

- Material:** Blank = Plated Steel, S = 316 Stainless Steel
- Type:** Blank = Valved, P = Plain (unvalved) - nipple only
- Series:** 77
- Body:** C = Coupler, N = Nipple
- Body Size:** 4 = 1/4"
- End Fitting Type\*:**
  - 4F = 1/4" Female NPTF
  - 6F = 3/8" Female NPTF
  - SF562CX = 9/16" Female Medium Pressure
  - SF375CX = 3/8" Female Medium Pressure
  - SM562CX = 9/16" Male Medium Pressure
  - SM375CX = 3/8" Male Medium Pressure
  - M562C = 9/16" High Pressure Male
  - RH9 = 9/16" Reverse Cone
  - RH12 = 3/4" Reverse Cone
  - RH16 = 1" Reverse Cone
  - F250C = 1/4" Female High Pressure
  - M250C = 1/4" Male High Pressure
- Seals:** Blank = Nitrile, V = Fluorocarbon
- Special Option:** EN = Electroless Nickel Plating

\*Contact QCD for availability of other end configurations

## End Fittings

### Pressures to 10,000 psi (689 bar)

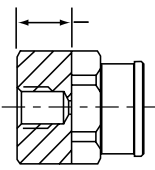
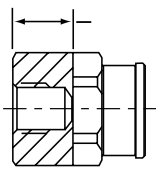
			
<b>1/4" NPTF</b>		<b>3/8" NPT</b>	
<b>in</b>	<b>mm</b>	<b>in</b>	<b>mm</b>
.75	19.05	.85	21.59

### Pressures to 20,000 psi (1379 bar)

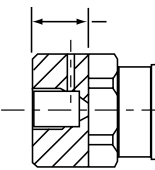
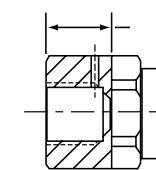
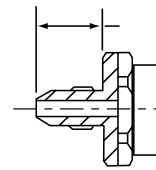
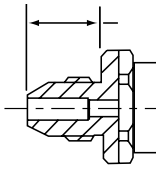
							
<b>3/8 MP SF375CX</b>		<b>9/16 MP SF562CX</b>		<b>3/8 MP SM375CX</b>		<b>9/16 MP SM562CX</b>	
<b>in</b>	<b>mm</b>	<b>in</b>	<b>mm</b>	<b>in</b>	<b>mm</b>	<b>in</b>	<b>mm</b>
.75	19.05	.85	21.59	.88	22.35	1.00	25.40

### Pressures (Steel) to 36,000 psi (2482 bar) - (SST) to 20,000 psi (1379 bar)

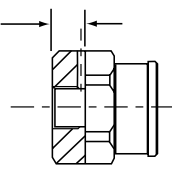
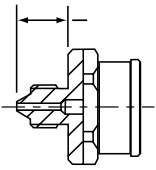
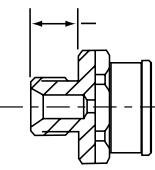
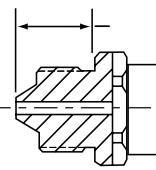
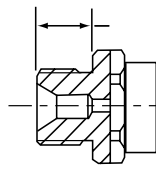
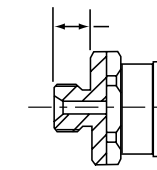
											
<b>1/4" HP F250C</b>		<b>1/4" HP M250C</b>		<b>3/4" REVERSE CONE (AUTOCLAVE RH12)</b>		<b>9/16" HP M562C</b>		<b>1" REVERSE CONE (AUTOCLAVE RH16)</b>		<b>9/16" REVERSE CONE (AUTOCLAVE RH9)</b>	
<b>in</b>	<b>mm</b>	<b>in</b>	<b>mm</b>	<b>in</b>	<b>mm</b>	<b>in</b>	<b>mm</b>	<b>in</b>	<b>mm</b>	<b>in</b>	<b>mm</b>
.45	11.43	.69	17.53	.63	16.00	1.12	28.45	.78	19.81	.50	12.70



2012年开始Snap-Tite签约中国代理商: 信德迈科技(北京)有限公司  
地址: 北京朝阳区望京 SOHO-T1-C 座 2115 室 邮  
编:100102手机: 139 1096 2635 电子邮件: sales@cnmec.biz

