

Needle Valves

Medium Pressure

QS Series

Pressures to 15,000 psi (1034 bar)

Since 1945 Parker Autoclave Engineers has designed and built premium quality valves, fittings and tubing. This commitment to engineering and manufacturing excellence has earned Parker Autoclave Engineers a reputation for reliable efficient product performance. Parker Autoclave Engineers has long been established as the world leader in high pressure fluid handling components for the chemical/petrochemical, water-blast, research, and oil and gas industries.

Medium Pressure Valve Features:

- Compression Sleeve to 15,000 psi (1034 bar).
- Tubing sizes available from 1/4" to 1".
- Rising stem/barstock body design.
- Non-rotating stem prevents stem/seat galling.
- Anti-galling molybdenum disulfide coated gland nuts.
- Gland nut positioning mark for assembly.
- Connection weep holes for safety and leak detection.
- Metal-to-metal seating achieves bubble-tight shut-off, longer stem/seat life in abrasive flow, greater durability for repeated on/off cycles and excellent corrosion resistance.
- PTFE encapsulated packing provides dependable stem and body sealing.
- Stem sleeve and packing gland materials have been selected to achieve extended thread cycle life and reduced handle torque.
- Choice of Vee or Regulating stem tip.
- Available in two body patterns.
- 1" valve bodies are 2507 Super Duplex standard

Parker Autoclave Engineers valves are complemented by a complete line of fittings, tubing, check valves and line filters. The QS Series uses Parker Autoclave Engineers' Quick Set compression sleeve design, providing fast easy make-up and reliable bubble-tight performance in liquid or gas service.



www.autoclave.com

Needle Valves - QS Series
Medium Pressure

Needle Valves - QS Series

Pressures to 15,000 psi (1034 bar)

Tube Outside Diameter Size Inches	Connection Type	Orifice Size Inches (mm)	Rated C_v^*	Pressure Rating psi (bar) @ Room Temperature**
1/4	QS 250	0.125 (3.18)	0.31	15,000 (1034)
3/8	QS 375	0.219 (5.56)	0.75	15,000 (1034)
9/16	QS 562	0.359 (9.12)	2.80	15,000 (1034)
3/4	QS 750	0.516 (13.10)	5.20	15,000 (1034)
1	QS 1000	0.688 (17.48)	5.20	15,000 (1034)

Notes:

* C_v values shown are for 2-way straight valve pattern. For 2-way angle patterns, increase C_v value 50%. (Based on water)

** For complete temperature ratings see pressure/temperature rating guide in Technical Information section.

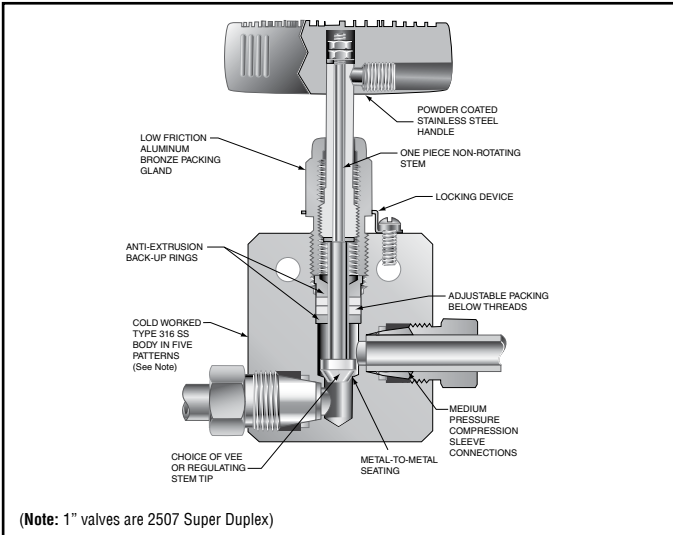
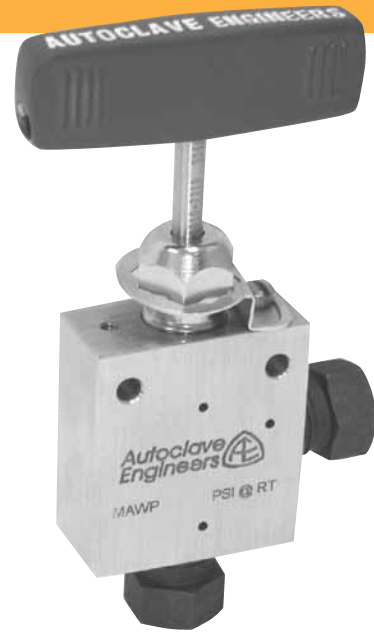

To ensure proper fit use Parker Autoclave Engineers tubing

Generalized Flow Coefficient Curves (C_v)

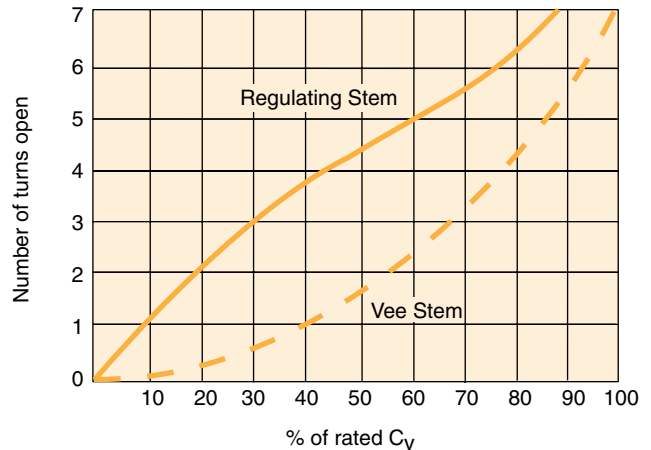

Ordering Procedure

For complete information on available stem types, optional connections and additional valve options, see Needle Valve Options section or contact your Sales Representative. QS Series valves are furnished complete with connection components, unless otherwise specified.

Typical catalog number: **15QS4071**

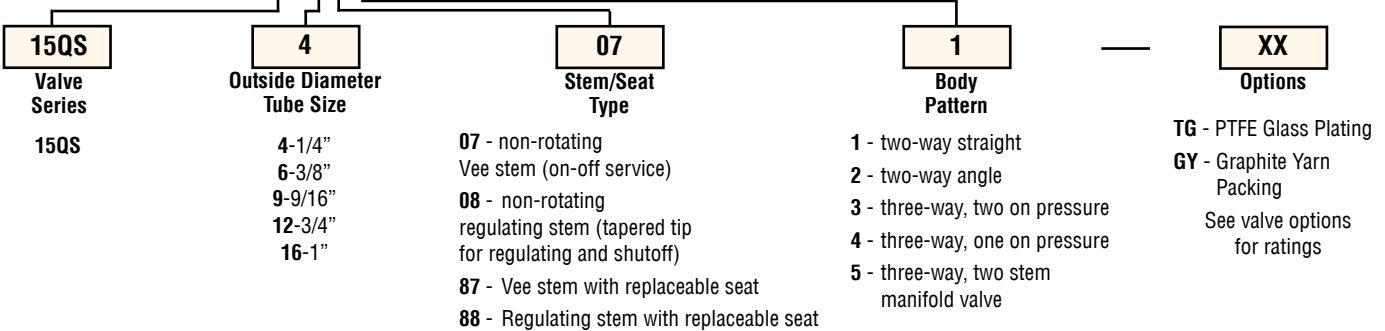

Valve Options

Extreme Temperatures

Standard Parker Autoclave Engineers valves with PTFE packing may be operated to 450°F (232°C). High temperature packing and/or extended stuffing box are available for service from -100°F (-73°C) to 650°F (343°C) by adding the following suffixes to catalog order number.†

TG standard valve with PTFE glass packing to 600°F (316°C).

GY standard valve with graphite braided yarn packing to 650°F (343°C).

B standard valve with cryogenic trim materials and PTFE packing to -100°F (-73°C).

†Parker Autoclave Engineers does not recommend compression sleeve connections below -100°F (-73°C) or above 650°F (343°C). For additional valve options, contact your Sales Representative.

Valve Maintenance

Repair Kits: add “R” to the front of valve catalog number for proper repair kit.
(Example: **R15QS4071**)

Valve Bodies: Valve bodies are available. Order using the eight (8) digit part number found on the valve drawing or contact your Sales Representative for information.

Consult your Parker Autoclave Engineers representative for pricing on repair kits and valve bodies.

Catalog Number	Stem Type	Outside Diameter Tube	Orifice Diameter	Dimensions - inches (mm)												Block Thickness	Valve Pattern
				A	B	C	D	D ₁	E	F	G	G ₁	H*	M	N		

2-Way Straight

15QS4071	VEE	1/4	0.125	2.00	1.00	0.38	1.62	1.19	2.00	3.00	0.75	0.22	4.69	0.62	0.38	0.75	See Figure 1
15QS4081	REG	(6.35)	(3.18)	(50.80)	(25.40)	(9.53)	(41.15)	(30.23)	(50.80)	(76.20)	(19.05)	(5.59)	(119.13)	(15.75)	(9.65)	(19.05)	
15QS6071	VEE	3/8	0.219	2.00	1.00	0.47	1.62	1.19	2.00	3.00	0.75	0.22	4.63	0.62	0.38	0.81	
15QS6081	REG	(9.53)	(5.56)	(50.80)	(25.40)	(11.94)	(41.15)	(30.23)	(50.80)	(76.20)	(19.05)	(5.59)	(117.60)	(15.75)	(9.65)	(20.57)	
15QS9071	VEE	9/16	0.359	3.00	1.50	0.53	2.38	1.75	3.00	4.00	1.00	0.34	6.05	0.69	0.50	1.25	
15QS9081	REG	(14.29)	(9.12)	(76.20)	(38.10)	(13.46)	(60.45)	(44.45)	(76.20)	(101.60)	(25.40)	(8.64)	(153.67)	(17.53)	(12.70)	(31.75)	
15QS12071	VEE	3/4	0.516	4.12	2.06	0.62	3.00	2.25	3.88	10.25	1.12	0.44	7.13	0.88	0.63	1.50	
15QS12081	REG	(19.05)	(13.11)	(104.65)	(52.32)	(15.75)	(76.20)	(57.15)	(98.43)	(260.35)	(28.45)	(11.18)	(180.98)	(22.35)	(16.00)	(38.10)	
15QS16071	VEE	1	0.688	4.75	2.38	1.19	3.75	2.63	4.75	10.25	1.12	0.44	8.00	0.88	0.63	2.00	
15QS16081	REG	(25.40)	(17.48)	(120.65)	(60.33)	(30.18)	(95.25)	(66.68)	(120.65)	(260.35)	(28.45)	(11.18)	(203.20)	(22.35)	(16.00)	(50.80)	

Note: 1" valve bodies are 2507 Super Duplex

2-Way Angle

15QS4072	VEE	1/4	0.125	2.00	1.00	0.38	1.19		2.44	3.00	0.75	0.22	4.81	0.62	0.38	0.75	See Figure 2
15QS4082	REG	(6.35)	(3.18)	(50.80)	(25.40)	(9.53)	(30.23)		(61.98)	(76.20)	(19.05)	(5.59)	(122.17)	(15.75)	(9.65)	(19.05)	
15QS6072	VEE	3/8	0.219	2.00	1.00	0.47	1.20		2.56	3.00	0.75	0.22	4.93	0.62	0.38	0.81	
15QS6082	REG	(9.53)	(5.56)	(50.80)	(25.40)	(11.94)	(30.48)		(65.02)	(76.20)	(19.05)	(5.59)	(125.22)	(15.75)	(9.65)	(20.62)	
15QS9072	VEE	9/16	0.359	3.00	1.50	0.53	1.69		3.50	4.00	1.00	0.36	6.55	0.69	0.50	1.25	
15QS9082	REG	(14.29)	(9.12)	(76.20)	(38.10)	(13.46)	(42.88)		(88.90)	(101.60)	(25.40)	(9.14)	(166.37)	(17.53)	(12.70)	(31.75)	
15QS12072	VEE	3/4	0.516	4.12	2.06	0.62	2.19		4.63	10.25	1.12	0.44	7.88	0.88	0.63	1.50	
15QS12082	REG	(19.05)	(13.11)	(104.65)	(52.32)	(15.75)	(55.58)		(117.48)	(260.35)	(28.45)	(11.18)	(200.15)	(22.35)	(16.00)	(38.10)	
15QS16072	VEE	1	0.688	4.75	2.38	1.19	3.75		5.38	10.25	1.12	0.44	8.63	0.88	0.63	2.00	
15QS16082	REG	(25.40)	(17.48)	(120.65)	(60.33)	(30.18)	(95.25)		(136.53)	(260.35)	(28.45)	(11.18)	(219.25)	(22.35)	(16.00)	(50.80)	

Note: 1" valve bodies are 2507 Super Duplex

G - Packing gland mounting hole drill size
G₁ - Bracket mounting hole size
Panel mounting drill size: 0.22" all valves.

* H Dimension is with stem in closed position.
** 1/8" straight and 3-Way/2 on pressure valves have offset tube connections

For prompt service, Parker Autoclave Engineers stocks select products. Consult factory.
All dimensions for reference only and subject to change.

